



Working Radius 16.0m

Max Lifting Height 16.8m

Capacity 3.83t x 2.7m

Weight 5600-5750kg

**MC405**

The MC405 is a very powerful Mini Crane with an outstanding 3.83 tons of lifting capacity. This fantastic model has a unique Pick and Carry feature of up to 500kg. The optional fly jib increases the already impressive working range even further. It also features an option of a class-leading Searcher Hook with 850kg capacity.

- 3.83 Ton Max Capacity
- 16.8m Max Working Height
- 20.7m With Optional Fly Jib
- 500kg Pick & Carry Duty
- Energy Saving System
- Sheaves Protected Inside Boom
- Variable (Hi/Lo) Travel Speeds
- Programmable Moment Limiter
- Centralized Controls
- 4 Fall / 2 Fall Hook Block
- Automatic Hook Stowage System
- Tilt Alarm
- Powerful Two Speed Winch with Hydraulic Disc Brake
- Digital Feedback Remote Control
- Outrigger Interlock System
- Optional 500kg / 850kg Searcher Hook
- Data Logger
- 2 Year Warranty

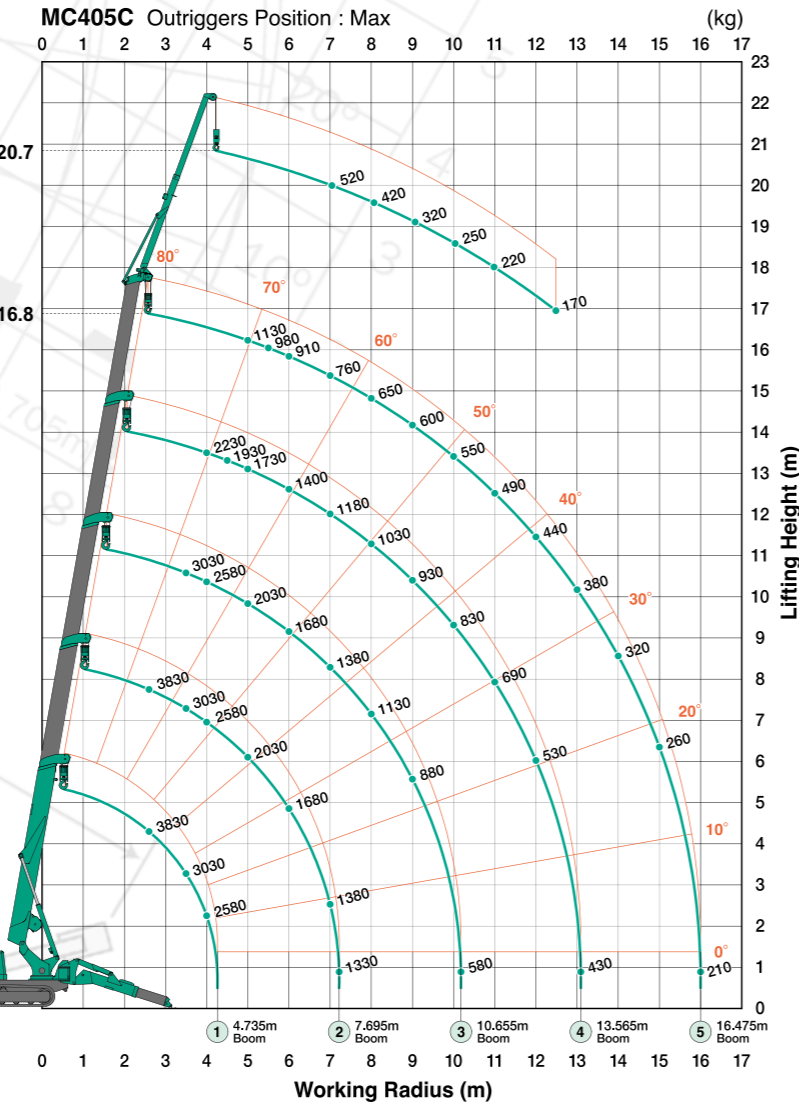
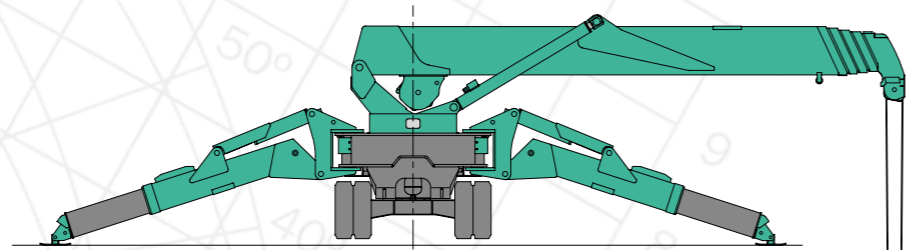

This working range chart shows total rated load including boom and jib deflection.

**Total rated load with Outriggers at Maximum position with 850kg Searcher Hook**

Working radius (m)	Total rated load (kg)				
	4.735m boom	7.695m boom	10.655m boom	13.565m boom	16.475m boom
2.7	850	850			
3.5	850	850	850		
4.0	850	850	850	850	
4.6	850	850	850	850	
5.0		850	850	850	850
6.0		850	850	850	850
7.5		850	850	850	670
8.0			850	850	620
10.5			550	760	490
13.4				390	340
14.0					310
15.0					250
16.3					170

**Total rated load Outriggers at Maximum position**

4.735m/7.695m boom		10.655m boom		13.565m boom		16.475m boom	
Working radius (m)	Total rated load (kg)	Working radius (m)	Total rated load (kg)	Working radius (m)	Total rated load (kg)	Working radius (m)	Total rated load (kg)
< 2.7	3830	3.5	3030	4	2230	5	1130
3.5	3030	4	2580	4.5	1930	5.5	980
4	2580	5	2030	5	1730	6	910
5	2030	6	1680	6	1400	7	760
6	1680	7	1380	7	1180	8	650
7	1380	8	1130	8	1030	9	600
7.25	1330	9	880	9	930	10	550
		10.2	580	10	830	11	490
				11	690	12	440
				12	530	13	380
				13.1	430	14	320
						15	260
						16	210

**Total rated load Outriggers at Middle position**

4.735m/7.695m boom		10.655m boom		13.565m boom		16.475m boom	
Working radius (m)	Total rated load (kg)	Working radius (m)	Total rated load (kg)	Working radius (m)	Total rated load (kg)	Working radius (m)	Total rated load (kg)
< 2.7	3830	3.5	3030	4	2230	5	1130
3.5	3030	4	2580	4.5	1830	5.5	980
4	2580	5	1880	5	1630	6	910
5	1880	6	1430	6	1330	7	730
6	1430	7	1130	7	1080	8	630
7	1160	8	880	8	880	9	550
7.25	1120	9	740	9	730	10	480
		10.2	490	10	530	11	430
				11	480	12	380
				12	430	13	330
				13.1	330	14	280
						15	220
						16	180

**Total rated load Outriggers at Minimum position**

4.735m/7.695m boom		10.655m boom		13.565m boom		16.475m boom	
Working radius (m)	Total rated load (kg)	Working radius (m)	Total rated load (kg)	Working radius (m)	Total rated load (kg)	Working radius (m)	Total rated load (kg)
< 2.7	3830	3.5	3030	4	2230	5	1130
3.5	3030	4	2580	4.5	1830	5.5	980
4	2580	5	1680	5	1630	6	880
5	1680	6	1180	6	1180	7	730
6	1180	7	880	7	830	8	530
7	930	8	730	8	680	9	450
7.25	780	9	580	9	550	10	420
		10.2	400	10	430	11	370
				11	380	12	330
				12	350	13	280
				13.1	310	14	240
						15	190
						16	150

### Outrigger Footprints

Diagram shows outriggers at maximum position.

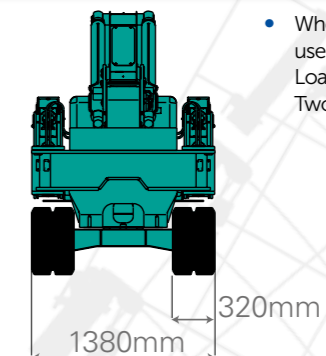
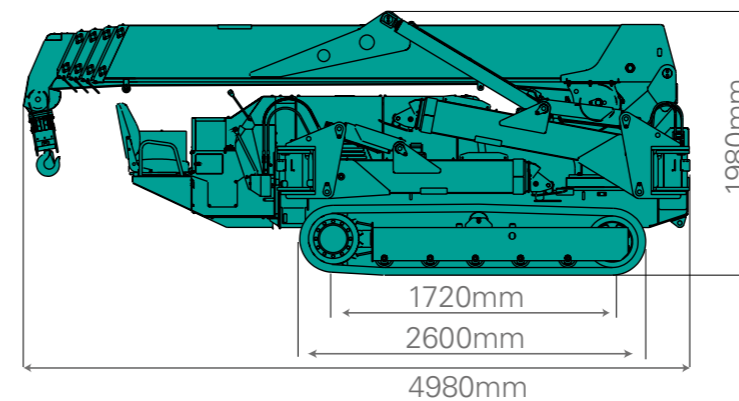
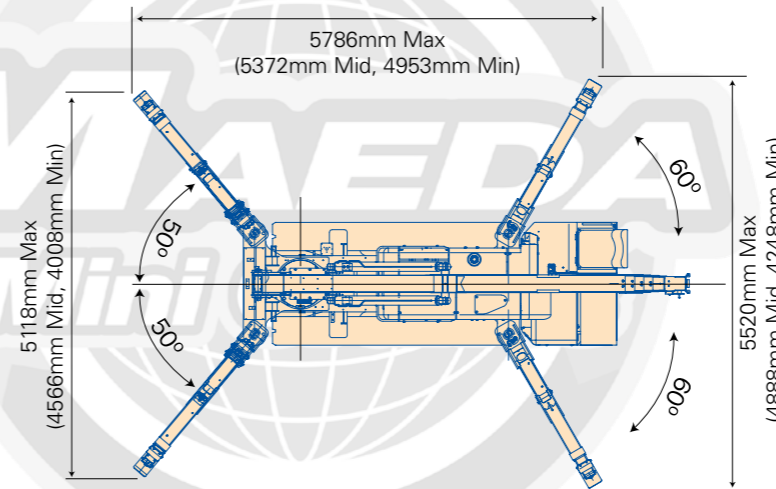

- When using two fall or single fall hooks, use the appropriate four fall Total Rated Load Chart but with a maximum load of: Two Fall - 1930kg, Single Fall - 970kg.

# MC405

## Specifications

Capacity	Maximum	3.83 t x 2.7m
Working radius	Maximum	16.0m x 210kg
Lifting height	Maximum	16.8m x 1130kg (20.7m x 520kg with Fly-Jib)
Dimensions	MC405 CRM/E	4980mm x 1380mm x 1980mm
Weight	MC405 CRM MC405 CRME Hook block weight Fly-Jib	5600kg 5750kg 50kg 150kg
Hook speed	Maximum	18m / min (4 falls, 4th layer)
Single line speed	Maximum	72m / min. (4th layer)
Hoist rope	Type	IWRC 6 x WS (26) Ø 8mm x 92m
Telescopic system	Boom length Telescoping speed Boom type	4.735m - 16.475m 11.7m / 41.3 sec Fully automatic 5 section pentagonal telescopic boom
Boom hoist system	Hoist angle / speed	0° - 80° / 17 sec
Slew system	Slew angle / speed	360° continuous / 2.5 rpm
Outrigger system	Type Maximum outriggers	Extension and set-up by hydraulic cylinders (Length) 5786mm x (Front) 5118mm x (Rear) 5520mm
Traction system	Drive Travel speed Gradability Ground length x width Ground pressure	Hydraulic motor driven, stepless speed changer 0 - 3.3 km/h 20° 1720mm x 320mm (Track dimensions) 0.50 kgf / cm <sup>2</sup> (0.52 kgf / cm <sup>2</sup> CRME)
Engine	Model Type Rated output Starting method Fuel tank capacity	Yanmar 3TNV88-BPMB 3 cylinder water cooled diesel 21.4 kW / 2400 rpm Electric Diesel / 60L
Electric motor (Optional)	Type Size	Fully enclosed fan cooled motor 7.5 kW 4P 380V
Safe load indicator	Made specifically for Maeda Mini Cranes with a fully programmable working envelope	
Standard equipment	Overwind protection, hydraulic safety valves, level, tilt alarm, EMO switch, travel lock lever, outrigger interlock system, moment limiter, working status lamp, hour-meter, 4-fall / 2-fall hook block, black rubber tracks, digital feedback remote control, data logger	
Optional equipment	Fly-Jib Slew restrictor Radio remote control White rubber tracks 500kg / 850kg searcher hook Engine heater Hydraulic heater Single fall hook Large single fall hook (as for LC models) Spark arrestor Plastic machine cover	

